

New
Specification



Rewarding Learning

General Certificate of Secondary Education
2018

Centre Number

--	--	--	--	--

Candidate Number

--	--	--	--	--

GCSE Physics

Unit 1

Higher Tier



[GPY12]

GPY12

FRIDAY 15 JUNE, MORNING

TIME

1 hour 30 minutes.

INSTRUCTIONS TO CANDIDATES

Write your Centre Number and Candidate Number in the spaces provided at the top of this page.

You must answer the questions in the spaces provided.

Do not write outside the boxed area on each page or on blank pages.

Complete in black ink only. **Do not write with a gel pen.**

Answer **all** questions.

INFORMATION FOR CANDIDATES

The total mark for this paper is 100.

Figures in brackets printed down the right-hand side of pages indicate the marks awarded to each question or part question.

Quality of written communication will be assessed in Questions **4(a)** and **5(b)**.

11504



28GPY1201

1 (a) Two cars take part in a race over a distance of 500 m.

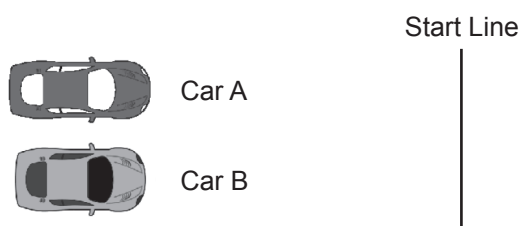

The time starts when Car A passes the start line.
Car B is given a penalty and waits for 2.0 s before it can pass the start line.
The distance–time graphs for both cars are shown below.

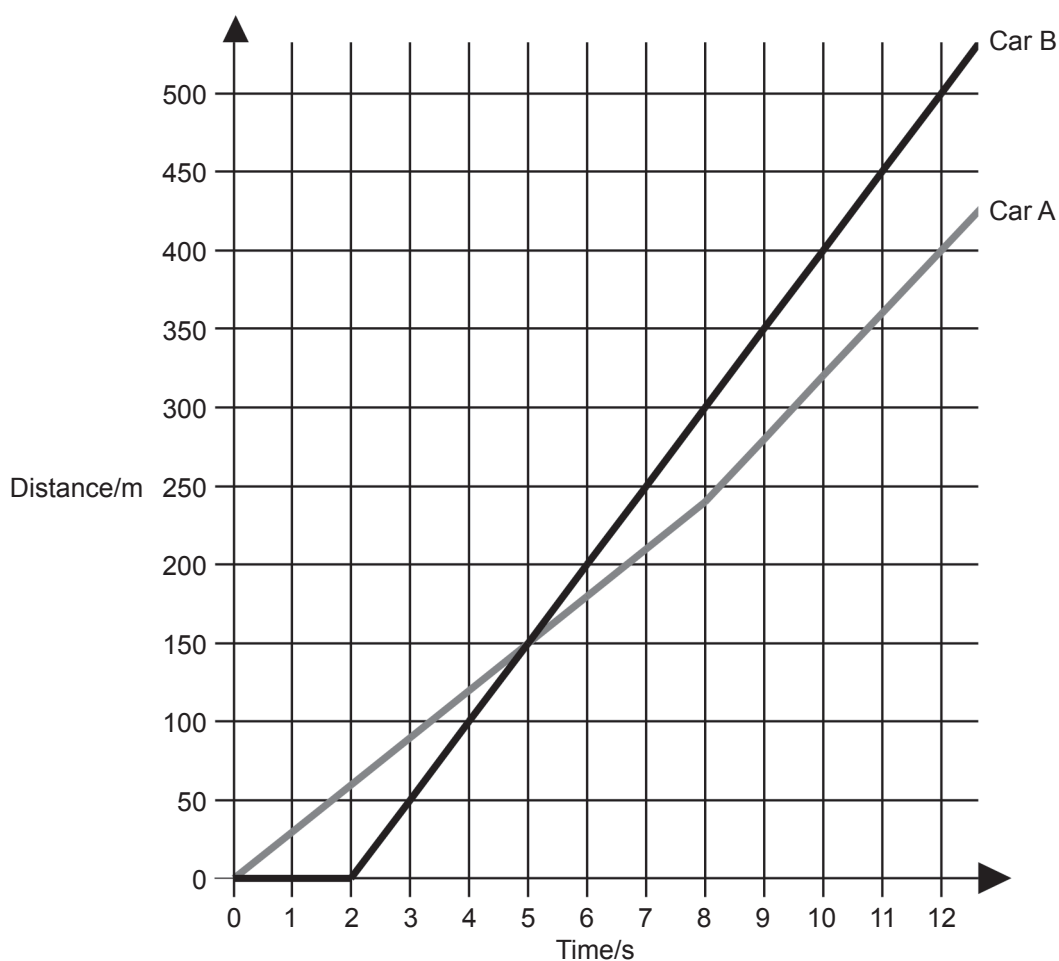

(i) How far ahead of Car A is Car B when it wins the race? _____ [1]

(ii) At what time does Car B overtake Car A? _____ [1]

(iii) Calculate the average speed of Car B, from the time it starts to move.
Show clearly your calculation, starting with the equation you plan to use to get your answer.

Average speed = _____ m/s [3]

(iv) On the grid opposite draw the distance–time graph for Car A if it is to travel at a constant speed and win the race 1.0 s ahead of Car B. [2]

(b) A ball is accelerating down a slope several metres long.
The slope has markings on its surface 1 m apart.

(i) Describe how you would use a stopclock to show that the ball is accelerating.

[2]

(ii) What would you do to improve the reliability of any measurements?

[1]

[Turn over



- (c) A car approaches a set of traffic lights just as they change from green to red. The graph below shows how the velocity of the car changes as the driver brakes and brings the car to a stop.

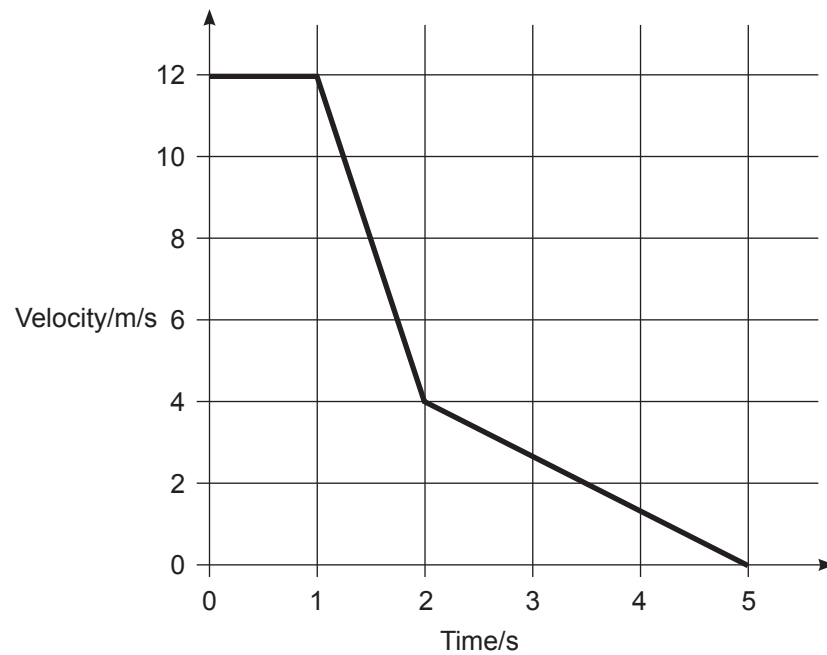

- (i) How long does it take the driver to react to the change in the traffic lights before applying the brakes?

_____ s [1]



- (ii) Using the graph, calculate the distance the car travels from the moment it starts to slow until it stops.
Show clearly your calculation, starting with the equation you plan to use to get your answer.

Distance = _____ m [3]

- (iii) The car did not decelerate at a constant rate.
Explain how the graph shows this.

_____ [1]



- (d) A car starts from **rest** and accelerates uniformly reaching a velocity of **28 m/s** after travelling **70 m**.

Calculate the following.

At each step you should show clearly your calculation, starting with the equation you plan to use to get your answer.

- (i) The average velocity of the car.

Average velocity = _____ m/s [3]

- (ii) The time it takes the car to travel the 70 m.

Time = _____ s [3]

- (iii) Calculate the acceleration of the car during this time.

Acceleration = _____ m/s² [3]



- 2 (a) The diagram shows a car moving along a straight level road. The arrows show the two horizontal forces acting on the car. The mass of the car is 750 kg.



Source: Chief Examiner

- (i) Calculate the acceleration of the car.
Show clearly your calculation, starting with the equation you plan to use to get your answer.

Acceleration = _____ m/s² [4]

- (ii) After a journey along the motorway and with the same forces acting as above, it is found that the acceleration is now greater than the value calculated in part (i).
Give a reason for this.

_____ [1]

[Turn over



- (b) To investigate how the acceleration of a trolley depended on the mass of the trolley, the apparatus shown below was set up. The trolley was pulled along by a constant force. The acceleration was measured using a light gate connected to a computer.

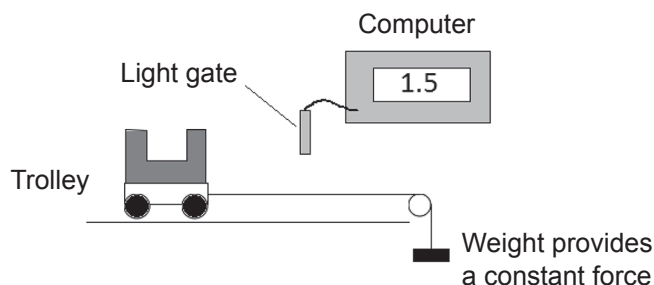

The results of the experiment are shown in the table below.

Mass of the trolley/kg	0.5	1.0	1.5	2.0	3.0
Acceleration m/s^2	1.2	0.6	0.4	0.3	0.2

- (i) On the grid opposite plot a graph of the mass of the trolley (x-axis) and acceleration (y-axis). Draw a curve of best fit through the points. [5]
- (ii) Which one of the following equations is the correct relationship between the acceleration **a** of the trolley and its mass **m**. Circle the correct one.

$ma = \text{constant}$

$ma^2 = \text{constant}$

$m/a = \text{constant}$

[1]



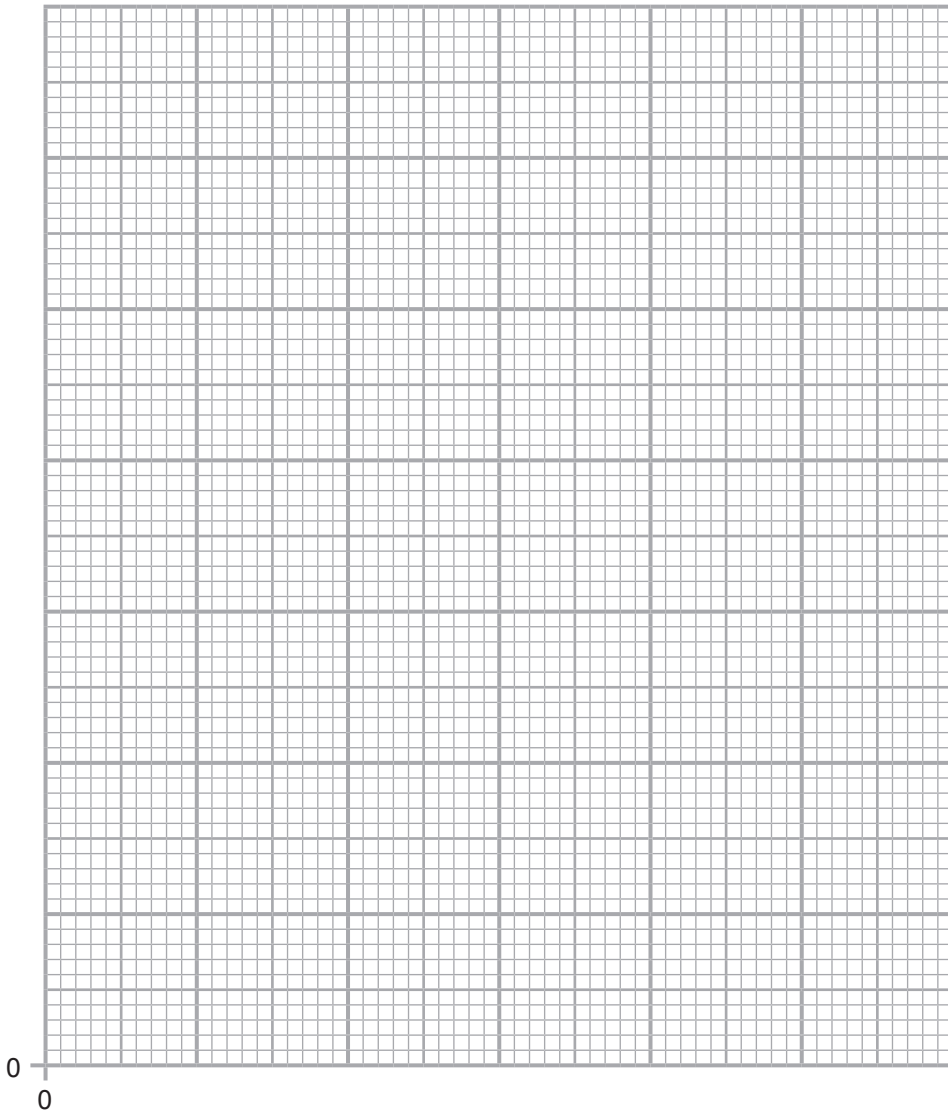

11504

[Turn over



28GPY1209

- (c) Three identical springs are suspended from a beam and various weights are added as shown in the diagram below.

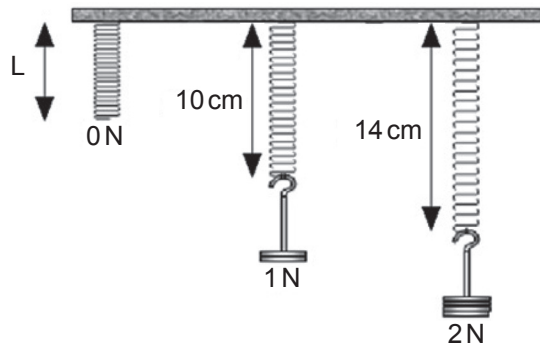

Source: Chief Examiner

- (i) Using the information from the diagram, calculate the unextended length L of the spring when no weights are attached.

Unextended length $L =$ _____ cm [2]

- (ii) Calculate the spring constant for the springs shown and state its unit. **Show clearly your calculation, starting with the equation you plan to use to get your answer.**

Spring constant = _____ [3]

- (iii) Using your answer to part (ii), calculate the force needed to give the spring an extension of 10 cm.

Force = _____ N [2]



(d) The diagram below shows a simple pressure relief valve.

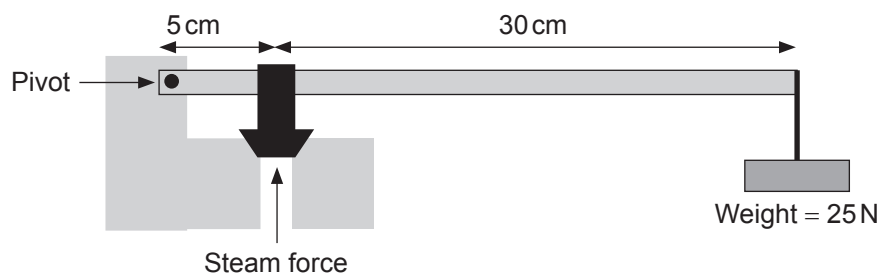

Source: Chief Examiner

When the steam pressure reaches a certain value the valve opens to reduce the steam pressure.

- (i) Using the Principle of Moments, calculate the size of the upward force exerted by the steam which will open the valve.
Show clearly your calculation, starting with the equation you plan to use to get your answer.

Upward force = _____ N [3]

- (ii) At another time the pressure of the steam was 36 N/cm^2 .
The area that the steam pressure acts on is 5 cm^2 .
Calculate the force exerted on the valve.
Show clearly your calculation, starting with the equation you plan to use to get your answer.

Force = _____ N [3]

[Turn over



- 3 (a) A student was asked to find the density of a liquid using the apparatus shown below.

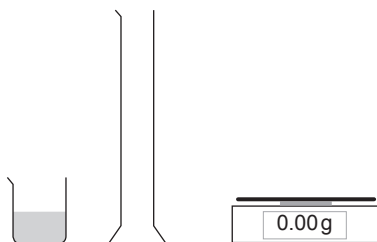

Source: Chief Examiner

- (i) However, the student writes down the measurements but does not record them in an organised way, as shown below.

50 cm³ 125 g 85 g 40 g

Place the measurements on the correct line below.
One has been done for you.

Mass of measuring cylinder = 85 g

Volume of liquid = _____

Mass of measuring cylinder and liquid = _____

Mass of liquid = _____

[2]

- (ii) Using the measurements above, calculate the density of the liquid.
Include the unit for density with your answer.

Show clearly your calculation, starting with the equation you plan to use to get your answer.

Density of liquid = _____ [4]



(iii) State how the student should accurately read the volume of water in the measuring cylinder.

[1]

(b) Use kinetic theory to describe carefully the difference between the motion of the molecules in water and the glass.

[3]

(c) A fixed mass of water was heated.
The density of water was measured at different temperatures.
The results of the investigation are shown in the graph below.

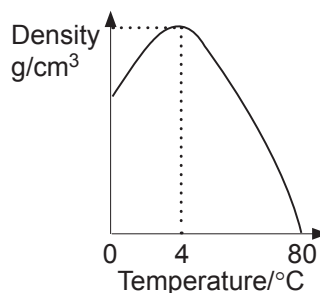

Describe how the volume of water changes.

From 0°C to 4°C _____

From 4°C to 80°C _____ [2]

[Turn over



- 4 (a) Describe, in detail, how you would measure the personal power of a student by having the student climb a staircase or perform step-ups to a platform. **The weight of the student is known.**

In your description you should state:

- what apparatus you would use;
- what measurements you would make;
- how you would use these measurements to calculate the student's power.

In this question you will be assessed on your written communication skills including the use of specialist science terms.

Apparatus:

Measurements:



Calculation:

[6]

(b) Below is a list of energy resources. Indicate which are renewable and which are non-renewable by placing a tick (✓) in the appropriate box. The first one has been done for you.

Energy resource	Renewable	Non-renewable
Coal		✓
Tidal power		
Biomass		
Wind power		
Nuclear power		

[2]



- (c) A student uses her mobile phone.
Complete the energy flow diagram for the mobile phone.
Write the form of energy in the spaces provided.

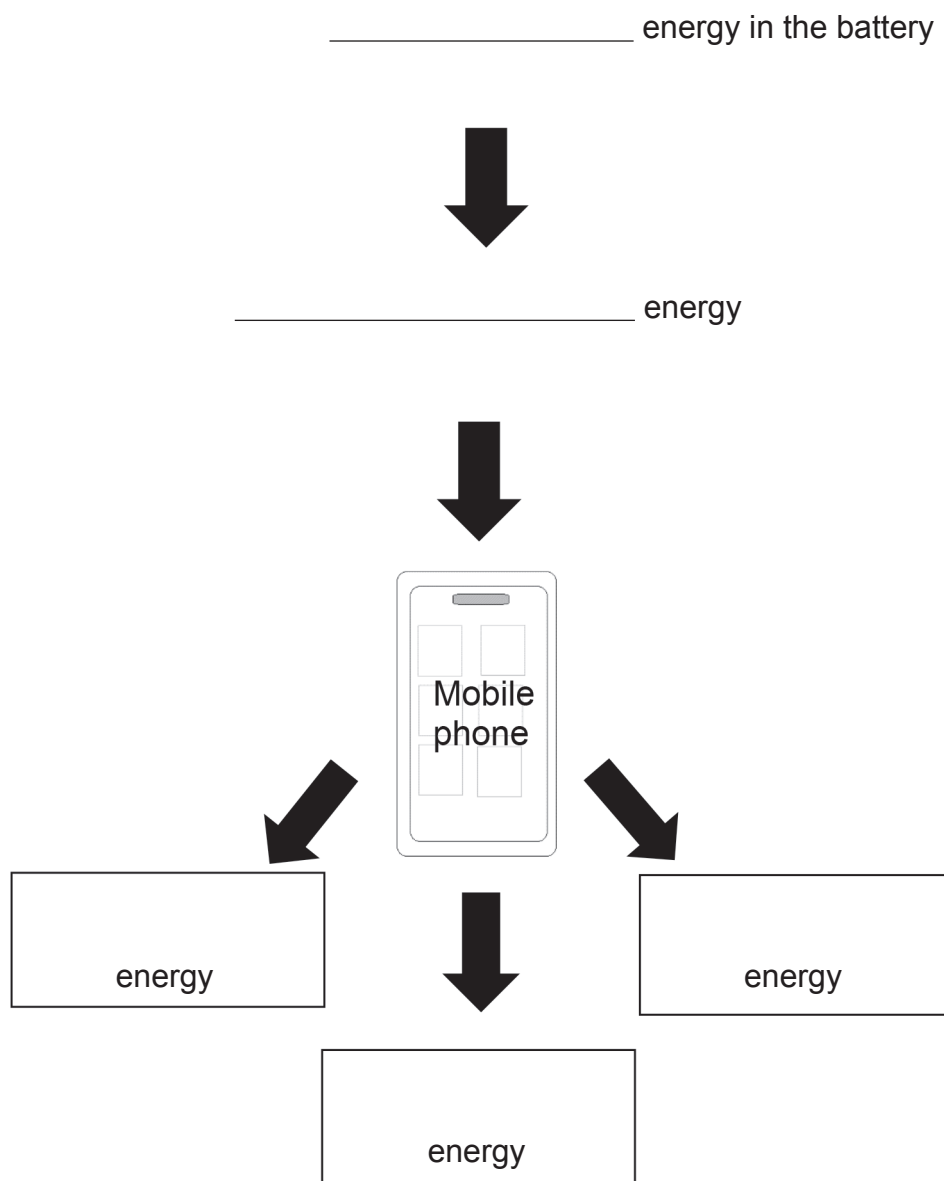

Source: Chief Examiner

[2]



(d) For every 240 J of input energy to a food blender, 144 J of useful kinetic energy are produced.
Calculate the efficiency of the blender.
Show clearly your calculation, starting with the equation you plan to use to get your answer.

Efficiency = _____ [3]

[Turn over

11504



28GPY1217

(e) A carriage is at the top of a roller coaster track **40 m** above the ground.
The mass of the carriage and passengers is **1200 kg**.

(i) Calculate the potential energy of the carriage and passengers.
Show clearly your calculation, starting with the equation you plan to use to get your answer.

Potential energy = _____ J [3]

(ii) At the bottom of the slope the carriage and passengers have a total kinetic energy of **$2.4 \times 10^5 \text{ J}$** . Show that its velocity is **20 m/s**.
Show clearly your calculation, starting with the equation you plan to use to get your answer.

[3]

(iii) When the brakes are applied, the carriage comes to a rest in **30 m**.
Calculate the friction force provided by the brakes.
Show clearly your calculation, starting with the equation you plan to use to get your answer.

Friction force = _____ N [3]



- (f) The thermal conduction by copper and glass can be compared using a computer and the apparatus shown below.
The glass and copper rods are of equal length and diameter.

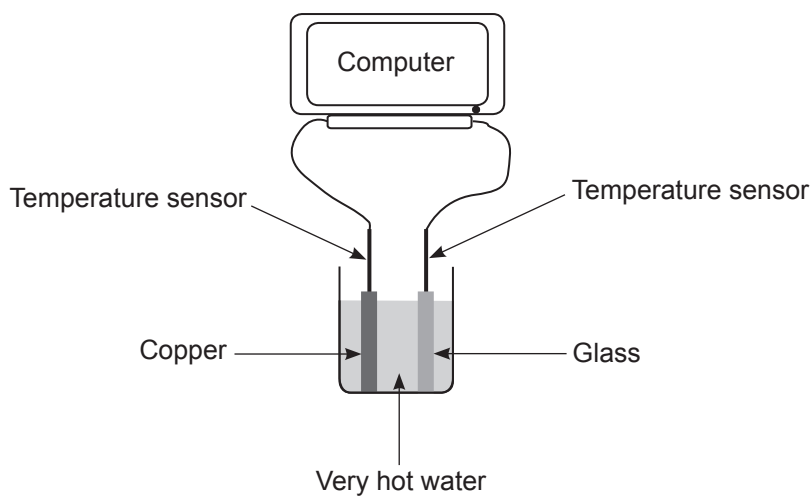

- (i) Using the axes below, sketch the two graphs that would be obtained, one for the copper and one for the glass. **Label each graph.** The temperature measured by the sensors is the same until the very hot water is poured into the tank.

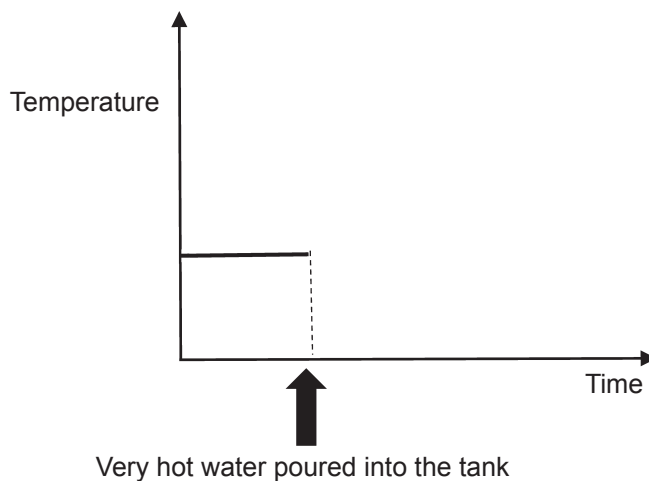

[1]

[Turn over



(ii) Describe the role particles play in the conduction of heat by copper.

[2]



- 5 (a) An experiment was completed to measure the half-life of a radioactive source. The corrected count rate in counts per second (cps) was recorded at set time intervals and used to plot a decay graph as shown below.

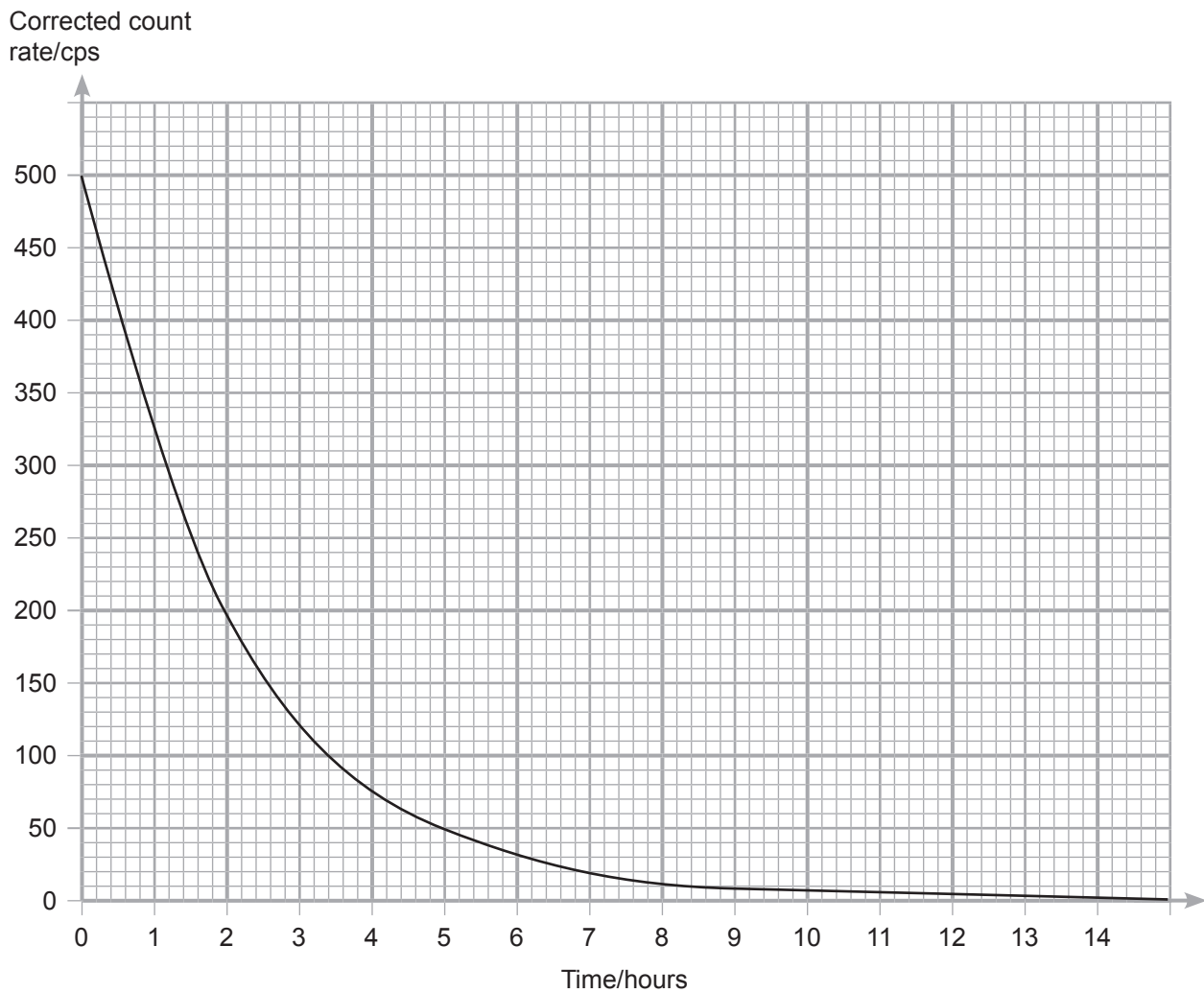

Use the graph to find a value for the half-life of the radioactive source.
You are advised to show clearly how you get your answer.

Half-life = _____ hours [2]

[Turn over



(b) Radioactivity is used in industry to control the thickness of aluminium sheet.

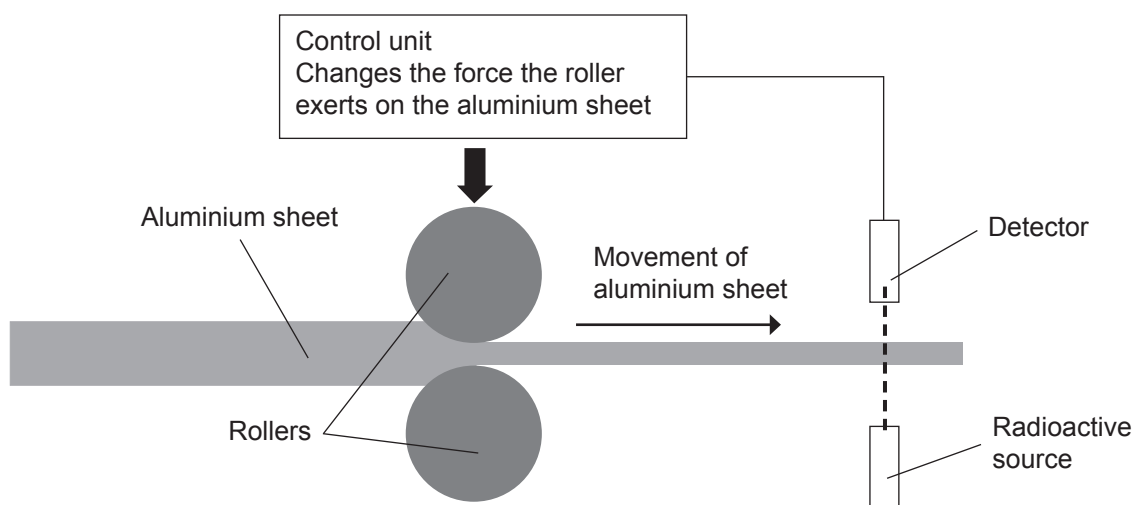

Discuss the properties of the radioactive source and how it is used to control the thickness of the aluminium sheet.

In your discussion you should:

- state the type of radiation (alpha, beta or gamma) used, giving a reason for your choice;
- explain why the half-life of the source is an important issue in the choice of radioactive source;
- describe how the count-rate measured by the detector is used to control the thickness of the aluminium sheet.

In this question you will be assessed on your written communication skills including the use of specialist science terms.

Radioactive source: _____





Half-life of the source: _____

Control of the thickness of the metal: _____

[6]



(c) The diagram below shows what happens when a heavy nucleus undergoes fission.

- (i) Label the particles involved.
Write their names in the boxes provided.

[2]

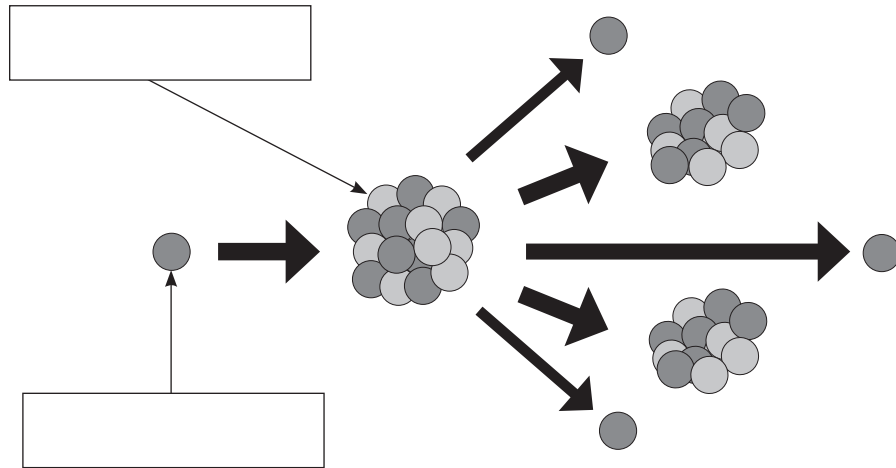

Source: Chief Examiner

- (ii) This fission reaction releases energy. What form does this energy take?

[1]

- (iii) Describe the role the particles above play in a chain reaction.

[2]



- (d) Nuclear fusion has the potential to provide very large amounts of energy. It is possible to fuse isotopes of hydrogen to produce another nucleus and release a lot of energy.

The diagram below shows a fusion reaction involving isotopes of hydrogen. Write the names of the isotopes in the boxes provided.

[2]

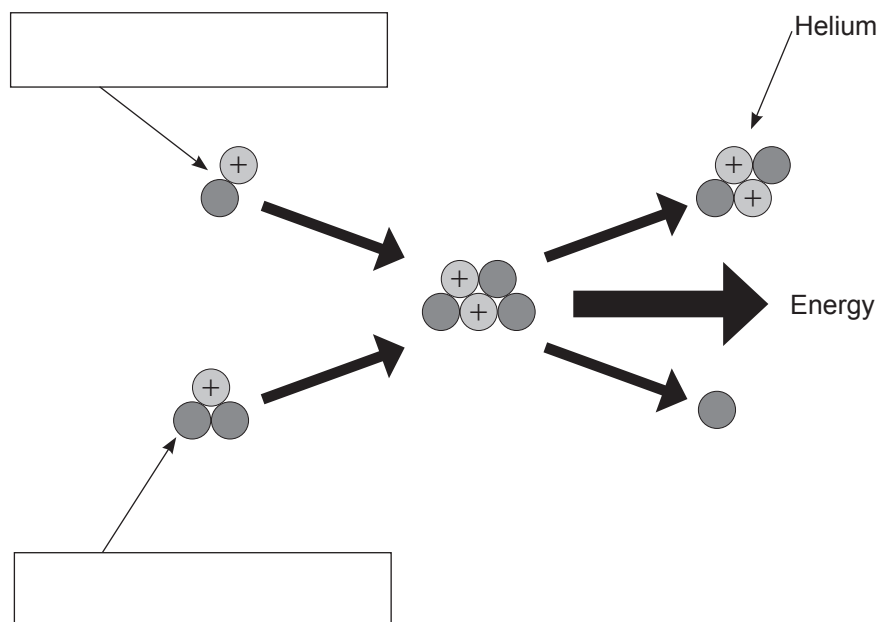

Source: Chief Examiner

THIS IS THE END OF THE QUESTION PAPER



BLANK PAGE
DO NOT WRITE ON THIS PAGE

11504



28GPY1226





BLANK PAGE
DO NOT WRITE ON THIS PAGE

11504



28GPY1227

DO NOT WRITE ON THIS PAGE

For Examiner's use only	
Question Number	Marks
1	
2	
3	
4	
5	

Total Marks	
--------------------	--

Examiner Number

Permission to reproduce all copyright material has been applied for.
In some cases, efforts to contact copyright holders may have been unsuccessful and CCEA will be happy to rectify any omissions of acknowledgement in future if notified.

236171



28GPY1228